



TIMBER FENCING

Almost every homeowner would like attractive fencing of one sort or another around their property. The fencing may be for reasons of privacy, or to prevent children and pets roaming too freely, or simply to act as a boundary marker.

It can be used to divide up part of a large garden, to hide the compost heap, or provide something for plants to grow up in a protected area. It can be decorative, functional, or a combination of both.

Whatever the reason for your fencing needs, Wickes provide a wide variety of fencing materials and numerous accessories to make the installation of fencing easy.



BEFORE YOU START

Fencing can be divided into two categories, (a) Ready made panels which simply need to be fitted between posts and (b) fencing which you basically make yourself from loose materials.

Ready made panels

Lap panels are available in four heights, 3, 4, 5, and 6' all being 6' long. (Approx. 900, 1200, 1500 and 1800 by 1800mm long). These panels consist of a timber frame with horizontally fixed overlapping larch slats. **FIG. 1 (overleaf)**.

The panels are pre-treated with preservative to give them a golden brown colour. They are always erected between evenly spaced posts.

Loose fencing materials

If ready-made panels are not used you can make your own fencing to almost any design that you wish.

Stockade fencing, **FIG. 2**, is simply 19 x 100mm fenceboarding fixed vertically to arris rails between posts which may be up to 2.4 metres apart. Between each piece of vertical timber there is a gap which can be as wide or narrow as you want.

Featheredge fencing, **FIG. 3**, is again vertical timber fixed to arris rails with each slat slightly overlapping the next providing complete privacy.

These styles of fencing are normally erected in 1.8 or 2.4m sections. Fuller details about how to make them are described later.

Palisade fencing, **FIG. 4**, is supplied by Wickes in kit form, each kit containing sufficient timber to make a 1753mm (5'9") long run just 914mm (3') high. An 864mm (2'10") wide matching gate for the Palisade Fencing is also available.

Trellis should not be ignored as a fencing material. Used in conjunction with conventional panels or on its own between posts it can form an attractive backdrop for climbing plants, or be built into a pergola type of garden feature. All trellises are 1829mm (6') long and come in three styles. These are the traditional square pattern, or diamond pattern at 1' high, and our bow trellis at 1'1" high each end and the arch top trellis at 1'6" high at the centre. **FIG. 5**. All make an attractive feature on top of a waney lap panel fence.

Fence Posts

Traditionally all fencing has been built using timber posts and Wickes stock pressure preserved posts in 1.5, 1.8, 2.1, 2.4 and 2.7m lengths. For every post you plan to use you will need a post cap. If a gate is included in your fencing project, use a Wickes 100mm (4") post for additional support.

KEEP INFORMED

- Look for other Good Idea Leaflets that could help you with your current project.
- Check that your Good Idea Leaflets are kept up to date. Leaflets are regularly changed to reflect product changes so keep an eye on issue dates.
- If you would like to be put on our mailing list for the Wickes Catalogue call
0845 274 1000
- Visit our website
wickes.co.uk

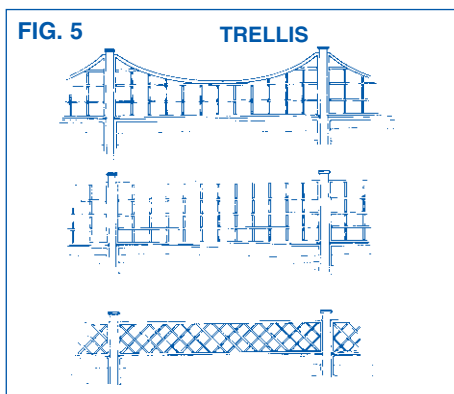
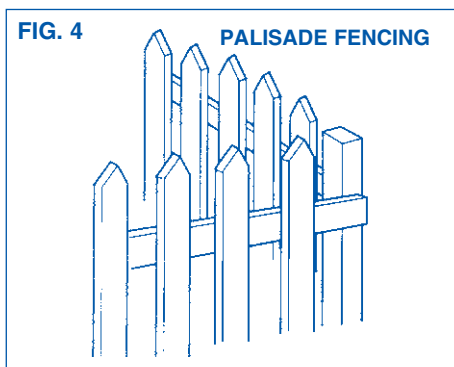
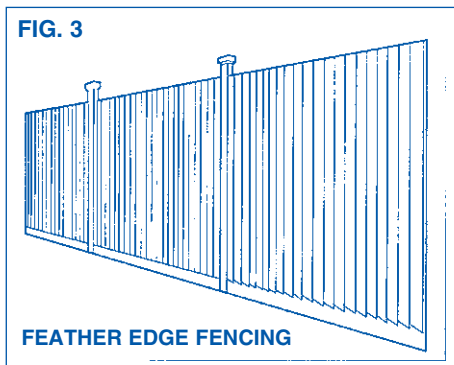
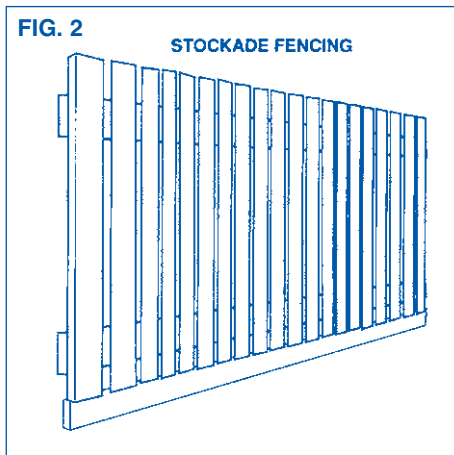
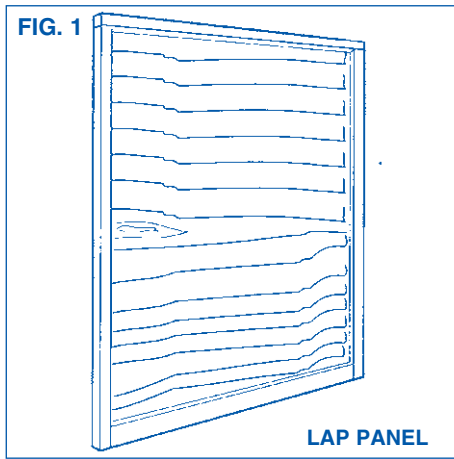

Concrete posts offer a stronger, totally rot free, alternative which can help make a fence more durable in severe weather conditions. Wickes stock a slotted concrete post for use with lap panels. If your fence post becomes damaged, you can always repair it rather than replace it with a Wickes repair spike.

Fencing accessories

The building of a fence is not just a question of knocking posts into the ground and nailing panels or pieces of timber to them. The effects of wind and weather will soon have such a fence flat on the ground. Any fence must be securely fixed to withstand the weather and for this reason, in order to make fence building as easy as possible and long lasting, Wickes stock a variety of special fencing accessories.

Perhaps the most important of these are our Gravel Boards. The concrete ones are 6' long x 6" high and designed for use with our slotted concrete posts and 6' panels. The fencing itself is fitted above the gravel board thus avoiding direct contact with the damp ground. We also stock pressure preserved timber fenceboarding for use as gravel boards. These are in 6' lengths to match the lap panels or 2.4 metres for self assembled fencing. Both are 150mm high.

However well the fencing timber is treated with a preservative, it cannot possibly last as long as it should if it is almost permanently wet. The use of a gravel board, concrete or timber, will prolong the life of a fence by many years. Timber still requires treating on a regular basis with a preservative.

Wickes Panel Fence Clips are used to attach framed fencing panels to timber posts. You will need four of these unique clips for 900 or 1200mm (3 or 4') panels and six for 1500 and 1800mm (5 and 6') panels. They are secured to the post and the panel with galvanised nails.

See **FIG. 6**.

They provide a far more effective method of securing the panels than nails alone. It is normal to use arris rails - triangular shaped timber - to provide the horizontal backing for featheredge or stockade type fencing. Our Arris Rail Brackets are used to connect the rails to timber fence posts. 38mm galvanised nails are used to secure the post to the bracket, and the bracket to the rail.

For years the only method of erecting timber fence posts was to concrete them into the ground. Invariably, the posts would eventually rot at ground level and both posts and concrete would have to be replaced. The modern way to fix timber posts is to use Metal Post Sockets. Two types are stocked by Wickes. The first is a fixed top post socket with a 600mm long spike which is driven into the ground. The socket remains above ground level and so therefore does the post which is clamped into it.

A sledgehammer is used to drive the post sockets into the ground. To protect the metal sides of the socket you need a 'dolly' - a chunk of strong timber or metal - which

fits into the socket and is hammered rather than the socket itself. Wickes stock a drive in tool just for that job. The second post support is a socket plate. This has the same socket at the top with a flat metal plate underneath. This is intended for fixing posts to a concrete base - a path or drive perhaps - using our Sleeve Anchors to secure the plate to the base. **FIG. 7** shows the basic socket fixings.

The spike type should not be used with 6' panels in very exposed and windy areas, must never be set in concrete, and should not be used in freshly dug ground.

If you do prefer to set your posts in a hole in the ground, perhaps replacing the old concrete block holding a long gone rotten old post, this is perfectly acceptable and our Postcrete will prove invaluable. You simply need to position the post in the hole, pour in a quantity of water, add the Postcrete and leave it for a few minutes to harden.

Remember, posts must be long enough to accommodate gravel boards at 150mm high, and any trellis that you may wish to add on top of fencing.

CUSTOMER CARE

Most fencing materials are a little on the rough side for handling so it is advisable to wear gloves to protect against splinters.

When driving in post supports the protective dolly may jump out of the socket top. Always ensure that it is properly seated. Keep other people well out of the way when swinging a sledgehammer.

WORK SEQUENCE

The work sequence varies very slightly for panel fencing and other types, but essentially is:-

1. Determine and mark out the boundary line
2. Put in the first fence post
3. Fix a second post and infill between the two
4. Proceed section by section
5. Treat bare timber

ERECTING PANEL FENCING

For the purposes of this leaflet it is assumed that post sockets will be used.

The first job with any fence building project is to determine the line of the fencing. On a property boundary, mark the boundary line using a piece of strong string or twine.

All your posts and fencing must be on your side of this boundary marker.

At the start of the fencing run drive in a post socket, keeping the clamp face of the support facing towards your side of the boundary line. Fit the first post into the socket and secure in place by tightening the bolt.

Temporarily prop the first panel against the post. Drive in a second post socket at the end of the panel, keeping the socket face aligned with the panel edge.

Remove the panel and fit the second post. Cut a gravel board to length to fit perfectly horizontally at ground level between the post sockets. Secure the gravel board to the socket at each end using timber fixing brackets and either black japanned or other plated round head screws.

Refit the panel between the posts on top of the gravel board and secure with the fence panel clips - two or three at each end. The triangular section of the clips slot behind the timber framing. The panel should be located centrally on the posts. Repeat the sequence for the remainder of the fencing run. Finally fit a post capping - available from Wickes - to each of the posts.

Should you wish to darken the colour of the fencing, apply an additional coat of Wickes Fence and Shed Treatment using either the Golden or Dark Brown shade. Other colours are available - please ask In-Store for details or check our website - www.wickes.co.uk.

MAKING YOUR OWN FENCING

Featheredge

Featheredge fencing consists of posts, post supports, arris rails and brackets, and gravel boards, plus featheredge boards.

The arris rails are available in 2.4m lengths. Although sections of fencing can be made up to this length it may be considered better to work in 1.8m runs in particularly exposed windy areas so that there is a shorter span between posts.

The featheredge boarding is available in 1.5, 1.8, and 2.4m lengths packed in bundles of 10/12 or sold separately. If a 1.2m high fence should be required the 2.4m lengths are cut in half. Similarly, if a 0.9m high fence is required, perhaps on top of walling, 1.8m lengths are cut in half.

For fences 1.5 metres high, three arris rails are required, for 1.8m high fences, four arris rails are required and for a 2.4m high fence five. The fence posts should be tall enough to cope with the height of the gravel board (150mm) and the featheredge boarding. These should be 100 x 100mm and need to set 600mm into the ground.

Unlike panel fence construction which is done section by section, featheredge fencing is done by erecting the main framework for the entire run before the boarding is fitted.

Start by marking the fence line as described previously. Drive in your first post socket at the starting point and fit a post. Using a length of arris rail as a guide to spacing, drive in a second post socket and fit another post. Connect the two posts with arris rails and arris rail brackets. The rails should be set back from the front face of the post by at least the thickness of the featheredge boarding. You should check that all your arris rails are exactly the same length, and are fitted perfectly horizontally. They should be positioned about 200mm from the top and bottom edges of the intended position of the featheredge boards.

Fit the first gravel board between the post supports as described for panel fencing but with the face flush with the front of the post. Continue building the framework to the end of the fence run. See **FIG. 8**.

The featheredge boarding can now be fitted. For a 2.4 metre run you will require 32 pieces of boarding. For a 1.8 metre run you will require 24 pieces of boarding. Each length overlaps the previous one by a minimum of 19mm. Start by securing the first length with its thick edge against the post at one end of the section. Use 38mm galvanised wire nails and ensure that they go into the centre of the arris rail.

Since it can be difficult to space out the lengths with equal overlaps and achieve a perfect fit at the opposite end it is suggested that all the remaining pieces are initially only lightly pinned to the top arris rail. Adjustments can then be made before the lengths are finally fixed.

At overlaps the nails should be driven in through the thick feather-board edge to miss the thin edge of the board behind, which could split. See **FIG. 9**.

To make the fence more attractive there is no reason why alternate panels should not have the thick edges of the featherboarding facing in opposite directions. This creates no construction problems, and merely means fixing the boards starting at a different end for each panel. Complete the fencing by fitting post cappings.

Stockade Fencing

This type of fencing is basically constructed in the same way as featheredge fencing with the framework of posts and arris rails being built first.

The 19 x 100mm fenceboards are packed in bundles of five, or sold separately in 1.8 and 2.4m lengths approx.

As mentioned previously the gap between boards can be varied to suit your requirements but as a guide to spacings and boards required the following may be a useful guide based on the 100mm board width:

Using 2.4 metre arris rails you will require 20 boards to leave a gap between boards of about 19mm, 18 boards to leave gaps of about 32mm, and 16 boards to leave spaces of about 47mm. This assumes that the end boards are not directly adjacent to the posts and the gaps between the posts and boards are also as above.

If using 1.8 metre lengths of arris rail cut from 2.4m pieces, you would need 15 boards to leave about 19mm gaps and 12 boards to leave about 46mm spaces. If wider spaces are required, reduce the number of boards accordingly.

For fences 1.5 to 1.8m high fences, four arris rails are required and for a 2.4m high fence five, but only three for lower fences unless they are in very exposed locations. The fence posts should be tall enough to cope with the height of the gravel board (150mm) and the featheredge boarding. These should be 100 x 100mm and need to set 600mm into the ground.

As explained with the overlapping of featheredge boards it can help to lightly pin the boards first to the top arris rail to ensure even spacing.

An alternative way to construct this type of fence is to fit the arris rails so that they finish flush with the front edge of the posts. The boards, including the gravel board, can then be fitted to the face of the framework along the entire run covering the post as well. See **FIG. 10**.

Finish the fence with cappings on all posts and treat as described for panel fencing if a different colour shade is wanted. All the posts should be fitted with a capping.

Our fencing products are listed overleaf. Use the list to create your own 'Picking List' In-Store. Note that imperial measurements are given where necessary to match sizes quoted in our Catalogue.

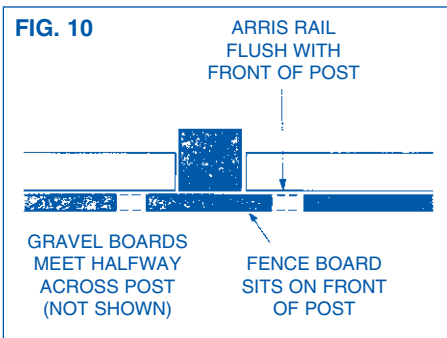
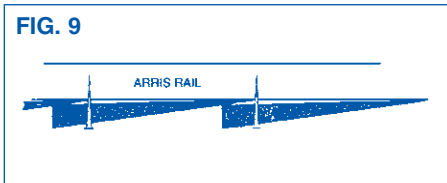
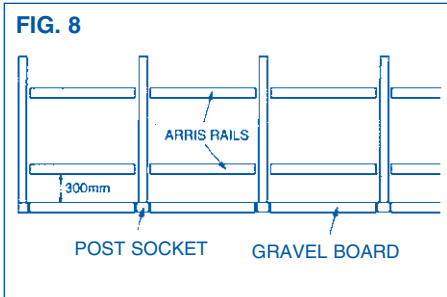
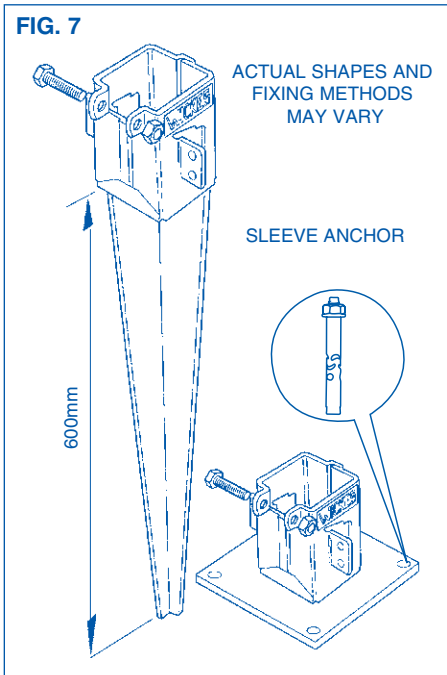
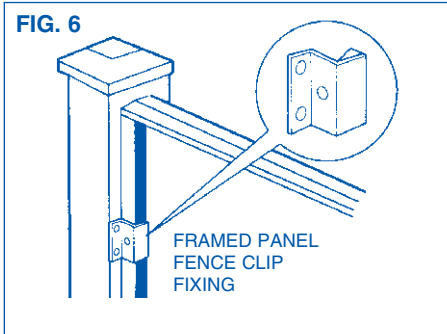

PROJECT SHOPPING LIST

Product	Size	Code	QTY
Overlap Panels	6 x 3'	540-050	
	6 x 4'	540-051	
	6 x 5'	540-052	
	6 x 6'	540-053	
Board Panel	6 x 6'	187-786	
Solway Panel	6 x 6'	187-787	
Lap Gate	6 x 3'	540-049	
Pre-Treated Timber Fence Posts			
75 x 75mm (Nominal)	x 1.5m	542-000	
	x 1.8m	542-001	
	x 2.1m	542-002	
	x 2.4m	542-003	
	x 2.7m	540-990	
100 x 100mm (Nominal)	x 2.1m	548-024	
	x 2.4m	540-991	
	x 2.7m	548-025	
Fencing Accessories			
Fence Post Cap single		540-054	
Acorn Post Finial pair		542-010	
Concrete Repair Spur		542-503	
Metal Repair Spike		542-505	
Slotted Concrete Fence Post 19 x 100mm (Nominal)	2.4m	540-063	
6" Concrete Gravel Board	1.8m	540-064	
Fenceboard/ Gravelboard			
19 x 100mm (Nominal)	Pack of 5	1.8m	107-062
	Single	1.8m	107-063
	Pack of 5	2.4m	107-064
	Single	2.4m	107-065
19 x 150mm (Nominal)	Pack of 5	1.83m	107-140
	Single	1.83m	107-141
	Pack of 5	2.4m	107-142
	Single	2.4m	107-143
Featheredge Fencing - 11 x 100mm (Nominal)			
Pack of 10	1.5m	107-082	
Single	1.5m	107-083	
Pack of 10	1.8m	107-084	
Single	1.8m	107-085	
Pack of 10	2.4m	107-086	
Single	2.4m	107-087	
Featheredge Accessories			
Arris rail - 37 x 75 mm (Nominal)	Pack of 4	2.4m	543-317
	Single	2.4m	543-318
Arris rail brackets		541-397	
Fence clips		541-399	
Metal Post Sockets			
24" Post Spike		542-500	
Dolly/Drive in Tool		542-502	
Bolt Down/Electa Plate		542-501	
Sleeve Anchors M10 x 100mm		510-235	
Postcrete	20kg	221-100	
Heavy Duty Trellis	6 x 1'	541-001	
	6 x 2'	541-000	
	6 x 3'	541-002	
	6 x 6'	541-004	
Decorative Trellis			
Diamond	6 x 1'	540-059	
Arch top	6 x 1'6"	540-016	

Things you may need - The following tools may be required for this job:

• Gloves • String or Twine • Sledge Hammer • Spade • Spirit Level • Tape Measure • Saw • Hammer • Screwdriver • Spanner

Wickes stocks a wide variety of the above. See In-Store or online at wickes.co.uk for details.

Whilst every care has been taken to ensure that the product design, descriptions, specifications and techniques of constructing the products are accurate at the date of printing, Wickes products will inevitably change from time to time and the customer is advised to check that the design, descriptions, specifications and techniques of constructing any of the products described in this leaflet are still valid at the time of purchase or placing an order.

© Wickes Building Supplies Limited 2011

All rights reserved. No part of this publication may be produced or transmitted in any form or by any means electronic, mechanical, photocopying, recording or otherwise or stored in any retrieval system of any nature without the written permission of the copyright holder and the publisher.