

## CORRUGATED ROOFING & CLADDING SHEETS

Wickes Clear Corrugated Roofing Sheet is very light in weight, simple to use and has high impact strength. There are two corrugation profiles – Standard and Mini, both these have a high light transmission and are resistant to yellowing.

Wickes Bitumenised Corrugated Sheet and Ridge pieces are made from an extremely tough, lightweight waterproof material. This product is made from organic and inorganic fibres saturated with bitumen whilst subject to intense pressure and heat.

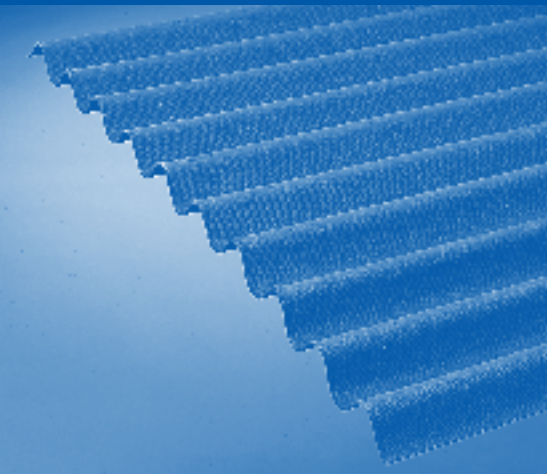

### WICKES BITUMENISED CORRUGATED SHEET AND RIDGE PIECES

The sheets are supplied in Matt Black or Green They have a 'woven' textured surface and are suitable for many roofing projects, whether it be for sheds, garages, lean-to's, carports, verandas etc.

They are also cheap enough for use as temporary roofing and cladding.

- Lightweight and easy to handle.
- Quickly fixed with special PVC headed nails.
- Ideal for new, existing or temporary roof coverings.
- Chemical and corrosion resistant.
- Rust, rot, and frost resistant.
- Cuts easily with a saw.
- Asbestos free.

### SIZE

Wickes Bitumenised Corrugated Roofing and Cladding Sheets are 2m long by 950mm wide, with a thickness of 2.8mm.

Ridge pieces are 900mm and also supplied in matt black or green.

Working with this product is extremely easy. The only tools you need are an ordinary wood saw, and a hammer – You don't even need a drill.

### WHERE TO USE

The sheets can be laid onto a roof structure of rafters and purlins or onto sheet decking. If the roof structure is not perfectly even, this will not create problems since the sheets are, to an extent, flexible and will withstand some bending to accommodate slight variations in levels. They can also be used as a Vertical Wall Cladding, ideally suited for sheds and other out buildings.

### WHICH WAY ROUND

Sheets should be laid with the tighter weave to the outside and the larger dimples\* on the underside – Why? See ventilation section.

### SAFETY

When working on this type of roof, a roof board should always be used to spread the load/ your weight across several supports. The roof board should also have a thick soft cushioning material attached to save damaging the roofing sheet.

Never handle or try and fix sheet materials in windy conditions. Even in a light wind, a large sheet will act like a sail, try and make this a two-man job.

### CUTTING

Lay the sheet on a flat surface mark out line of cut, provide good support on either side and cut using either an oiled coarse-toothed saw, or preferable a circular power saw.

### KEEP INFORMED

- Look for other Good Idea Leaflets that could help you with your current project.
- Check that your Good Idea Leaflets are kept up to date. Leaflets are regularly changed to reflect product changes so keep an eye on issue dates.
- If you would like to be put on our mailing list for the Wickes Catalogue call  
**0845 274 1000**
- Visit our website  
**wickes.co.uk**

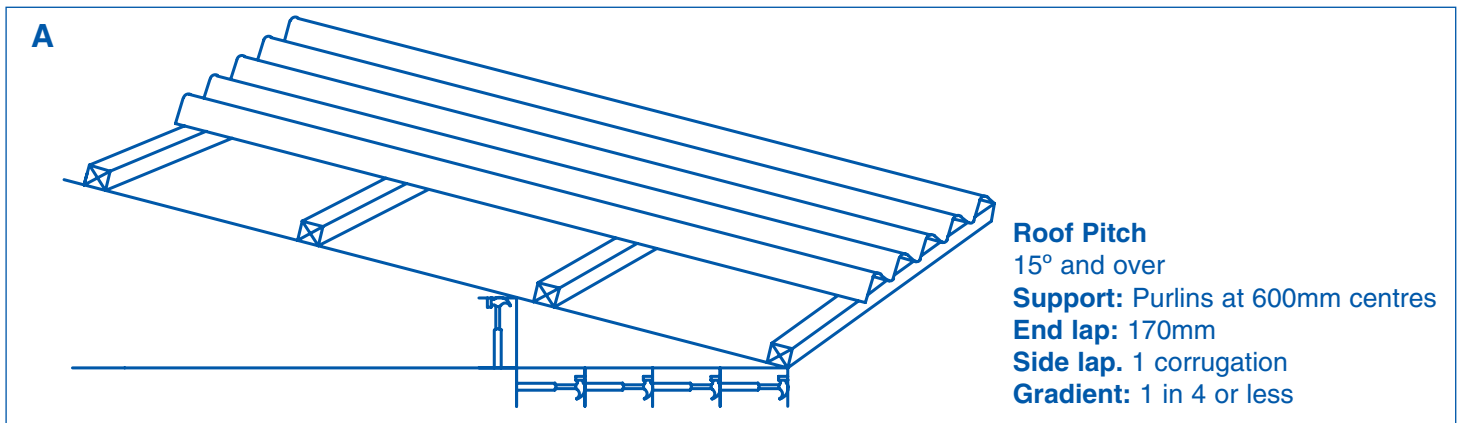

**Roof Pitch**

15° and over

**Support:** Purlins at 600mm centres

**End lap:** 170mm

**Side lap:** 1 corrugation

**Gradient:** 1 in 4 or less

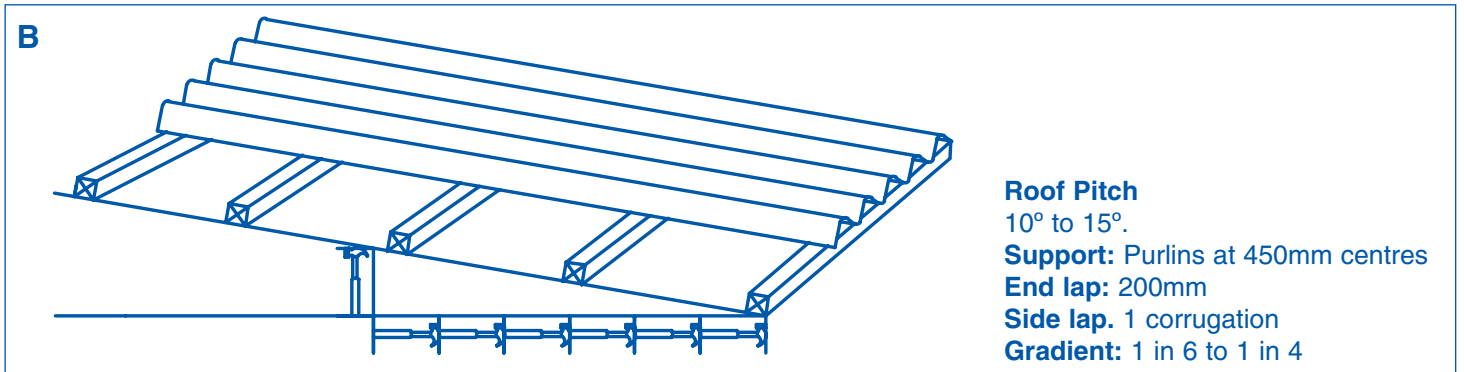

**Roof Pitch**

10° to 15°.

**Support:** Purlins at 450mm centres

**End lap:** 200mm

**Side lap:** 1 corrugation

**Gradient:** 1 in 6 to 1 in 4

**FIXING**

The sheets are fixed directly to timber with the special P.V.C. headed nails available.

No drilling of holes is required. The nails are driven straight through the sheets and the holes are sealed by the P.V.C. head of the special fixing nails.

Note: When used for roofing the nails must be driven through the crown (raised) part of the corrugations.

Important: If you nail through the valley of the sheet, it will leak!

**ROOF PITCHES, PURLINS AND OVERLAPS**

As with all roofing materials, Wickes Bitumenised Corrugated Sheet must be supported at regular intervals across their width using purlins. The spacing of those purlins depends upon the slope of the roof, and so does the amount by which each sheet overlaps the one below.

For a roof with a slope of 15° or more, purlins should be at 600mm centres and sheet end overlaps should be 170mm.

For a roof with a slope of 10 - 15° purlins must be no more than 450mm centres and each sheet should overlap the one below by 200mm.

In both of these examples, **Diagrams A** and **B**, side overlaps should be one corrugation. Where the roof slope is less than 10° [1 in 6] and never lower than 5° [1 in 11] **Diagram C** The roof sheets should be laid on a fully supporting plywood or similar approved roof decking, Note: As the fixing nails penetrate 25mm they must be nailed through the

decking into the purlins set at 450mm centres. The sheets should be lapped by 300mm with a two corrugation side lap. Note: Never use this type of sheeting on a roof with a pitch of less than 5°.

**SHEET FIXING**

The first (lowest) line of sheeting should be fixed so that the bottom edge overhangs the roof sufficiently far to enable rainwater to flow into a gutter or at least away from the side wall of the building. Overhangs should never be more than 70mm or strong winds may catch underneath and cause damage.

Start by nailing through the corrugations nearest the edge, at each side of the sheets, and then nail through the intermediate corrugations. At the bottom edge of each sheet every corrugation should be nailed. At purlins nail through every other corrugation. To avoid having to drive nails through four sheet thickness at overlap corners, the second row of sheets should commence with a half sheet. Cut the sheet by laying on a flat surface and score a line in the base of the fifth corrugation using a Stanley knife, complete separation by folding the sheet along cut line. The laying and nailing pattern is shown in **Diagram D**. Use a string line to keep fixings in line **Diagram E**.

At a ridge, cut the sheeting to length and fit the ridge pieces. These must be nailed through the sheeting into purlins, with nails at every corrugation. Overlap ridge pieces over each other by a least 125mm **Diagram F**.

**VERGE FIXING**

Fix a barge board level with the underside of the roofing sheets corrugation **Diagram G**. Fold down and nail in position.

**GUTTERING**

When draining into a gutter, a 65mm overhang for Wickes Roundline and Squareline guttering or 45mm for Wickes Mini Fit guttering is recommended. See Good Idea Leaflet 60 for information on gutters and their fixing.

**WATER FLOW**

As a rough guide, the maximum size of roof, that can be fed into, depending on the layout of the roof i.e. gutter on long or short size, is 24 – 34m<sup>2</sup> for a Mini gutter. 44-86m<sup>2</sup> for the Roundline gutter and 77-154m<sup>2</sup> for the Squareline gutter.

**VENTILATION**

When WBCR is used in areas of high relative humidity you should not seal the perimeter of the roofing. Adequate cross flow ventilation on the underside of the roofing is necessary to reduce the risk of condensation forming. Ventilation controls the build up of water vapour and if there is not sufficient air movement this will contact the underside of the roofing, which is likely to be the coldest surface in the building. The result of this is that water vapour condenses into water droplets. \*Wickes Bitumenised Corrugated Sheets have dimples on one surface designed to stop (or reduce, depending on the amount) water droplets from running down the sheet underside.

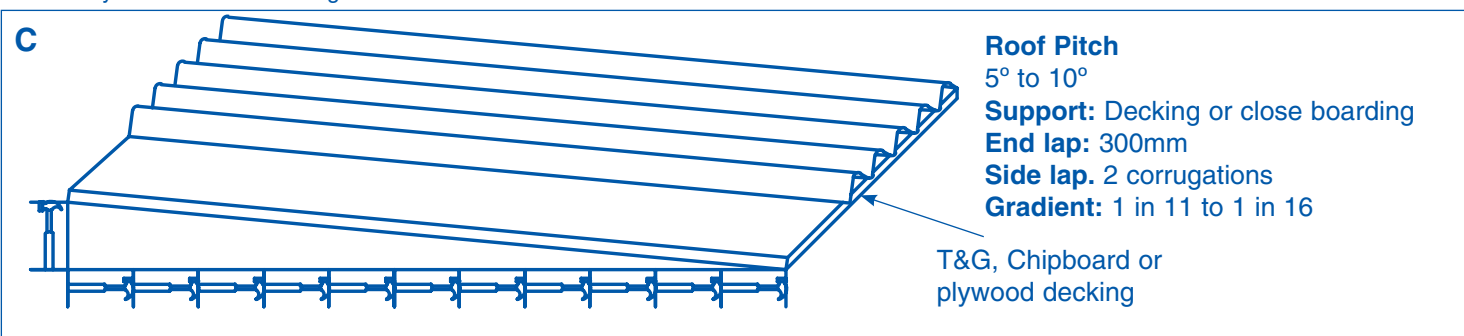

**Roof Pitch**

5° to 10°

**Support:** Decking or close boarding

**End lap:** 300mm

**Side lap:** 2 corrugations

**Gradient:** 1 in 11 to 1 in 16

T&G, Chipboard or plywood decking

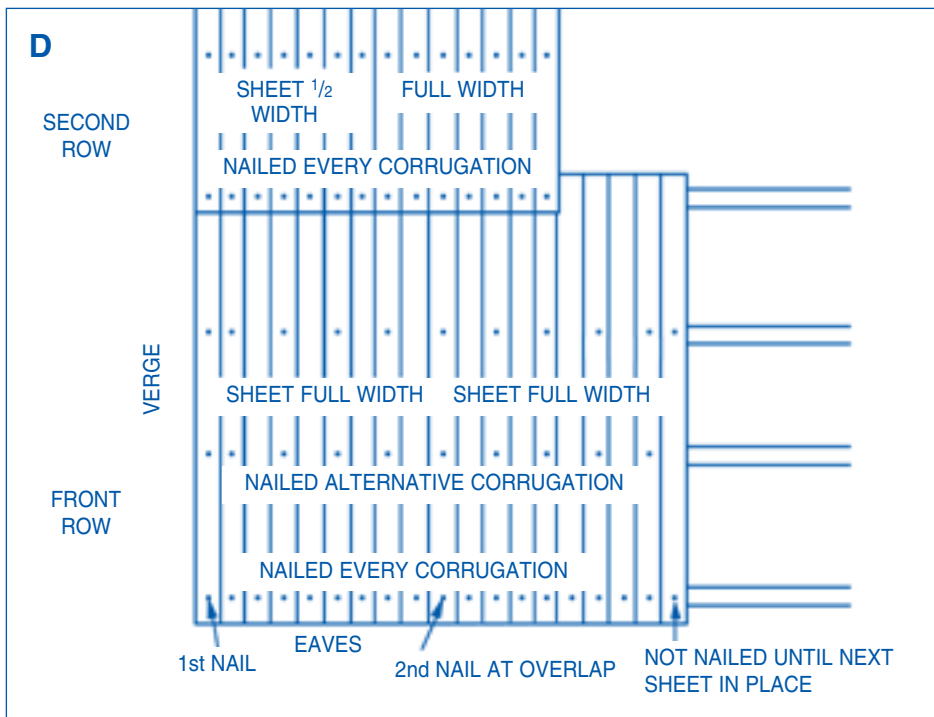

PRODUCT DESCRIPTION	PRODUCT CODE
Sheets - 2m x 950mm	
Black	240-039
Green	240-059
Ridge pieces - 900mm long	
Black	240-040
Green	240-058
Fixing nails	
Black pk20	240-025
Green pk20	240-099
Black pk100	240-085
Green pk100	240-089

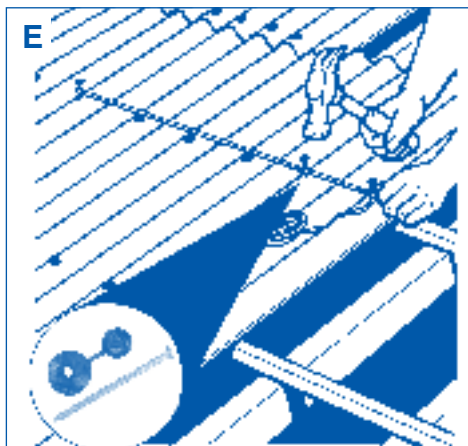

Autumn and early winter is when this risk of condensation forming is at its highest. This risk is often increased on new buildings with concrete floors as moisture is released into the structure during the period the concrete cures, often over several months. During cold periods the roofing sheets may have a surface temperature below freezing point, water vapour contacting this surface will be frozen. As the sun warms the roofing sheet, the ice will melt and create water droplets, which can be mistaken for leaking sheets or condensation. On buildings with a high risk of condensation formation we recommend that insulation and a vapour barrier should be incorporated into the roof design. It is advisable to seek professional advice on this.

In the event of condensation forming, there are two methods of control:

The first is to use roofing felt to create a secondary vapour barrier. This is fixed to the underside of the purlins with staples taking care to ensure it is taut with the minimum of slack. Overlaps should be a minimum of 100mm. At the rafters dress the felt down behind a treated batten and trim the edges, secure by nailing the batten the rafter. If the span between the rafters is greater than 600mm extra support will be required by using additional battens fixed to the underside of the purlins. Note: This system is not recommended if livestock can reach the felt.

The second, and easier method, is to cut and fit exterior grade plywood to the underside of the purlins. To support the sheets, nail treated timber battens to the rafters. If the span is too wide, additional cross batten supports will be required. All joints between sheets will require support.

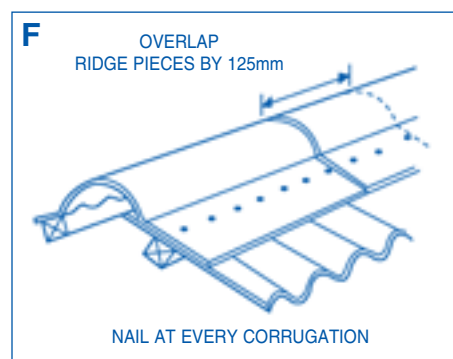

#### MAINTENANCE

To ensure long life the roof should be cleared of leaves other debris and gutters should be cleaned regularly.

#### CAUTION

Covering roofs can be a hazardous operation. All work must be carried out following health and safety regulations.

#### BUILDING AND PLANNING REGULATIONS

In some instances planning approval must be acquired on new and existing roofing projects, the material must be fixed in accordance with Building Regulations and relevant Codes of Practice, if in doubt seek professional advice or contact your Local Authority Building Control Office.

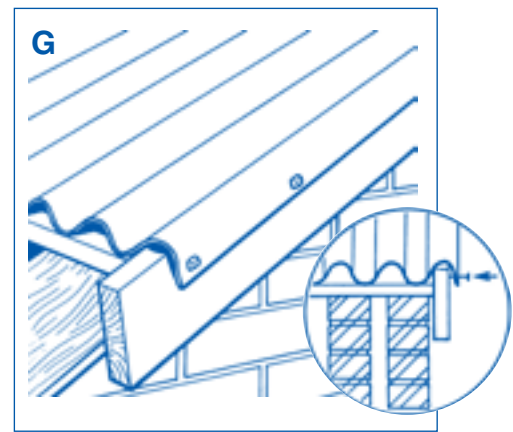

#### FIRE RESISTANCE

Wickes bituminous corrugated roofing sheets are not classified to External S.AA fire rating as required in UK Building Regulations for some classes of building such as housing; In these cases they must be fixed on a suitable fully supporting roof deck and the sheets coated with appropriate AA surface paint treatment, [as used for bituminous felted flat roofing], applied in accordance with the paint manufacturers instructions. If in doubt contact your local council Building Control Office, or seek professional advice.

## CLEAR CORRUGATED ROOFING

Wickes Clear Corrugated Roofing Sheet is readily available from all Wickes stores. This sheeting is very light in weight, simple to use and has high impact strength. There are two corrugation profiles – Standard and Mini, both these have a high light transmission and are resistant to yellowing.

Wickes Clear Corrugated sheets are ideal for porches, carports, covered walk ways etc. They are easy to use and economical.

#### STORAGE

Before use, store indoors on a flat dry surface in cool surroundings. When outdoor storage is unavoidable, store flat on wooden bearers spaced at about 1m centres and cover completely with an opaque light coloured tarpaulin. If stacked sheets are left uncovered in direct sunlight they will distort due to solar heat gain within the stack.

#### SUPPORTING STRUCTURES

Sheets must be fixed to supports spaced at centres not exceeding those given in table 2. Paints and wood preservatives applied to the supports must be thoroughly dried prior to fixing the sheets to avoid damage. Surfaces of supports immediately under the sheets must be light in colour, ideally white. A minimum slope of 5° is essential in any structure to allow water run-off, ideally the slope should be greater than 10°.

#### SAFETY

When working on this type of roof, a roof board should always be used to spread the load/your weight across several supports. The roof board should also have a thick soft cushioning material attached to save damaging the roofing sheet. Never handle or try and fix sheet materials in windy conditions. Even in a gentle breeze a large lightweight sheet will act like a sail, try and make this a two-man job. It may be necessary to weight the sheets while working with them.

## HOW TO USE

- The corrugations should always run from the highest point to the lowest and at a right angle to the \*purlins.
  - The amount of end and side overlaps depends upon the roof slope (see below).
  - Purlin spacing should be arranged so that the end laps are correct for the size of sheet being used.
  - Make sure all sheets are laid so that the side overlaps are away from the prevailing wind direction.
  - The purlins should be parallel and must be attached correctly to their supporting framework.
  - All sheet ends must be supported by a purlin. The eaves overhangs should never be greater than 300mm.
  - Never punch a hole, always drill through the crown part of the corrugated sheet. The hole should always be about 5mm larger than the fixing nail/screw to be used, this will allow for expansion and contraction of the sheet.
- \*Purlins - these are the secondary supports.

### Tip

1. Don't drill and fix in the valley of the sheet. If you do, it will leak!
2. Cutting or drilling very cold sheet could cause it to shatter. Take it out of the cold, let it warm up and then cut or drill.

If you are building a roof structure from scratch, make sure it is strong enough to support a heavy fall of snow, especially on shallow pitch roof such as a carport.

All fixings should be loosely secured at first, allowing a little movement. When all, or most, of the sheets are in place, and you are happy with the job, fix correctly, but don't over tighten.

### OVERLAPS

The amount a sheet is overlapped depends on the pitch of the roof, the shallower the angle, the greater the overlap should be. The following table is an approximate guide to the minimum overlap.

Roof Angle	End Overlap	Side Overlap
5 to 10°	300mm	2 corrugations
10 to 15°	200mm	1 corrugation
Over 15°	170mm	1 corrugation

Overlaps can be increased to facilitate a good fit and to reduce cutting, but never reduce overlaps, as this, in bad weather, will allow water to be blown through the joints. Whilst it is awkward, it is generally best to drill sheets in-place so that holes line up with the purlins and with each other. To allow for thermal movement, the fixing holes should be drilled about 5- 7mm larger than the fixings. Fixings should only be in the crown of ridges and NOT the valley. Always use a sealing washer, which is designed to stop rainwater seeping in, and specially designed spacers will reduce sheet distortion and lower the chance of over tightening. When drilling, always drill over a firm support using a slow speed drill fitted with a suitable, sharp drill bit. Don't push, let the drill do the work or you could split the sheet (especially if cold).

Whilst every care has been taken to ensure that the product design, descriptions, specifications and techniques of constructing the products are accurate at the date of printing. Wickes products will inevitably change from time to time and the customer is advised to check that the design, descriptions, specifications and techniques of constructing any of the products described in this leaflet are still valid at the time of purchase or placing an order.

© Wickes Building Supplies Limited 2011

All rights reserved. No part of this publication may be produced or transmitted in any form or by any means electronic, mechanical, photocopying, recording or otherwise stored in any retrieval system of any nature without the written permission of the copyright holder and the publisher.

## FIXING

Standard profile sheeting is fixed using special screws and sealing washers, whilst Mini profile is fixed using special nails and sealing washers. Both types of fixings are sold complete, in packs and are available from all Wickes stores.

With the sealing washer on the nail or screw fixing, place the fixing through the drilled hole in the crown of the corrugation. Then, gently screw or hammer the fixing into the purlin.

Note: The fixing should be tight enough to hold the sheet in position, but without distorting or damaging the corrugation.

Fix every corrugation at the sheet overlaps and at the top and bottom of the slope.

Centres may be reduced to alternative crown corrugation at immediate purlins. Use a taut piece of string to keep the fixings in a straight line across the sheet. Don't attach the top row or underlapping side fixings until the overlapping sheets are in place.

Always overlap the corrugated sheet sheets so that the top edge is pointing away from the prevailing wind. Use flashing where the sheet meets the wall at the top of the slope.

Foam Fillers should be used under the sheet at all support positions to prevent roof "chatter" and to support the sheet when it is fixed.

When using screws and caps to secure the sheet; the screws are sufficiently tight when the washer under its head can just be rotated with your finger and thumb.

### LAYING THE SHEETS

Make sure the purlins are the right size and at the correct centres (for the slope of the roof (given in Table 2). The position of purlins at the upper and lower ends of the roof and at the sheet overlaps are the critical points, there must be a purlin where you need to fix a nail or screw. When you have decided on the upper, lower and overlap purlins, evenly position the remaining purlins between.

Note: Make a few timber spacers of equal

Profile	Maximum Centres
3" Standard Profile	610mm
Mini Profile	525mm

length and use these to keep the purlins square to the eaves before fixing into position. It is important that you don't exceed the maximum support centres between the purlins. The sheets should first be loosely arranged on the roof (remember, even a gentle wind could lift them, so weight down if necessary) to give you an idea of fit and allow for adjustment. The end and side overlaps can be adjusted to avoid unnecessary cutting of the sheets; the overlaps can be increased to hide the excess - but not too much - and try to keep it even. At the same time, the positions of the fixings and any trimming cuts can be marked on the sheets with a felt-tip pen. Start by fixing sheets at the lower edge of the roof, preferably at the end away from the prevailing wind.

You may wish to create an access to something above that needs regular maintenance. This can be done by using a half

sheet and screw, not nail fixings.

Don't allow the sheet to overhang the fascia by more than 70mm. Any more than this and the wind will get underneath and cause problems.

Use a fine toothed handsaw to cut the sheet. Always follow the manufacturer's guidelines. A good idea is to practice cutting scrap pieces of material before starting. Lubricating with a general purpose oil can help prevent binding. Wickes Corrugated roofing sheet is supplied in two sizes 1.8, 2.4 & 3m x 600mm, so cutting can often be avoided by selecting the correct size at the planning stage. If you have to cut alternative ends sheets lengthways so that the vertical joints are staggered or where cutting across a sheet, lay one sheet on top of the other sheet to be cut and mark the cutting line. If the sheet has to be cut around projections, use a good quality, Wickes, fine toothed hand saw. Always support the sheet to minimise vibration and the possibility of splitting. Try cutting the sheet by sandwiching it between the others, leaving the part to be removed protruding from the stack, makes it easier to hold in place. Always try and hide cut edges under overlaps, if you can.

### FIXING RIDGES

Start fixing ridges at the end of the roof away from the prevailing wind. Overlaps should be approximately 120 - 130mm.

### VERGES

To prevent driving rain getting in, the sheets should overhang the verge by one corrugation but don't overhang the fascia by more than about 70mm, any more than this, strong winds will catch underneath this area and could cause damage.

Verges can be formed by fixing the final corrugation over a raised bargeboard, or by using a ridge piece to lay over the verge.

### GUTTERS

When draining into a gutter, a 65mm overhang for Wickes Roundline and Squareline guttering or 45mm for Wickes Mini Fit guttering is recommended. See Good Idea Leaflet 60 for information on gutters and their fixing.

### WATER FLOW

As a rough guide, the maximum size of roof, that can be fed into, depending on the layout of the roof, i.e. gutter on long or short size, is 24-34m<sup>2</sup> for a Mini gutter. 44-86m<sup>2</sup> for the Roundline gutter and 77-154m<sup>2</sup> for the Squareline gutter.

### GENERAL INFORMATION

Wickes corrugated sheeting can be used in temperature conditions from -20 to +60°C. When temperatures exceed 60°C distortion and discoloration can occur. Therefore false ceilings, insulation or other opaque materials should not be placed under the sheet. Use warm soapy water and a soft cloth or sponge for cleaning the sheets.