

# Wickes

**GOOD IDEA  
LEAFLET**

## INSTALLING GUTTERING & DOWNPIPES

Wickes gutters can be directly connected to many other manufacturers plastic gutters, without the need for special connectors. A compatibility chart listing the gutter systems on the market with which they are compatible can be found towards the end of this leaflet. The temptation is to keep

old guttering in use for as long as possible. Eventually it becomes inefficient and worn-out, perhaps even dangerous, requiring replacement. When that time arrives, or you need to fit new guttering to a conservatory or extension, this leaflet will help you understand the products and basic rules,

enabling you to fit the right guttering, safely, correctly, in a trouble free way.

Ideally, all guttering should be inspected twice a year. These inspections only take a matter of minutes and involve a routine look at the guttering systems condition.



### CHECKING & INSPECTION

**Autumn:** Check if fallen leaves and twigs have blocked the gutters and outlets, which could cause water to overflow, or pond on flat roofs. See Good Idea Leaflet 64 for flat roofs.

**Spring:** Look for signs of frost and wind damage, repair, or replace as necessary.

This is also a good time to check the condition of fascias and soffits. See Good Idea Leaflet 104.

What to do if you need new or replacement guttering:

- Read the rest of this leaflet
- Understand what's involved
- Decide whether to get someone to help, or call in a Tradesperson
- Plan and cost your job
- Make a shopping list
- Decide if you need to replace, repair or repaint any timber
- Don't be tempted to cut corners; this will probably cost you twice as much later on in time, effort and money
- Do the job correctly first time. With good preparation and materials it will last a long time
- Ensure you have adequate ladders or scaffolding for the job

Wickes stock a range of easy to install gutters and downpipes suitable for many domestic and commercial installations. Essentially these are a traditional half-round profile or the modern square section, using round and square downpipes. Wickes gutter systems have Simple wing clips in most connectors, to hold the guttering in place. This prevents sore fingers. It couldn't be easier

### ROUNDLINE GUTTERING

Wickes Roundline Guttering system is available in two sizes. 112mm & 76mm 112mm (4½") gutter is available with a 68mm (2½") round downpipe and is suitable for use on most domestic houses, conservatories and extensions. It is compatible with most existing metal or plastic systems (see chart on back page for details). Available in Black. 76mm (3") Minifit gutter is available with 50mm (2") downpipes and is suitable for collecting rainwater from small roof areas such as porches, bay windows, sheds, greenhouses etc. Available in Brown or Grey.

### SQUARELINE GUTTERING

Wickes Squareline Gutter was developed to allow greater water carrying capacity, with a distinct and different shape. Squareline gutter is 114mm (4½") wide and is available with

### KEEP INFORMED

- Look for other Good Idea Leaflets that could help you with your current project.
- Check that your Good Idea Leaflets are kept up to date. Leaflets are regularly changed to reflect product changes so keep an eye on issue dates.
- If you would like to be put on our mailing list for the Wickes booklet, call our Freephone number which is:  
**0500 300 328**
- Visit our website at [www.wickes.co.uk](http://www.wickes.co.uk)

**FIG. 1**

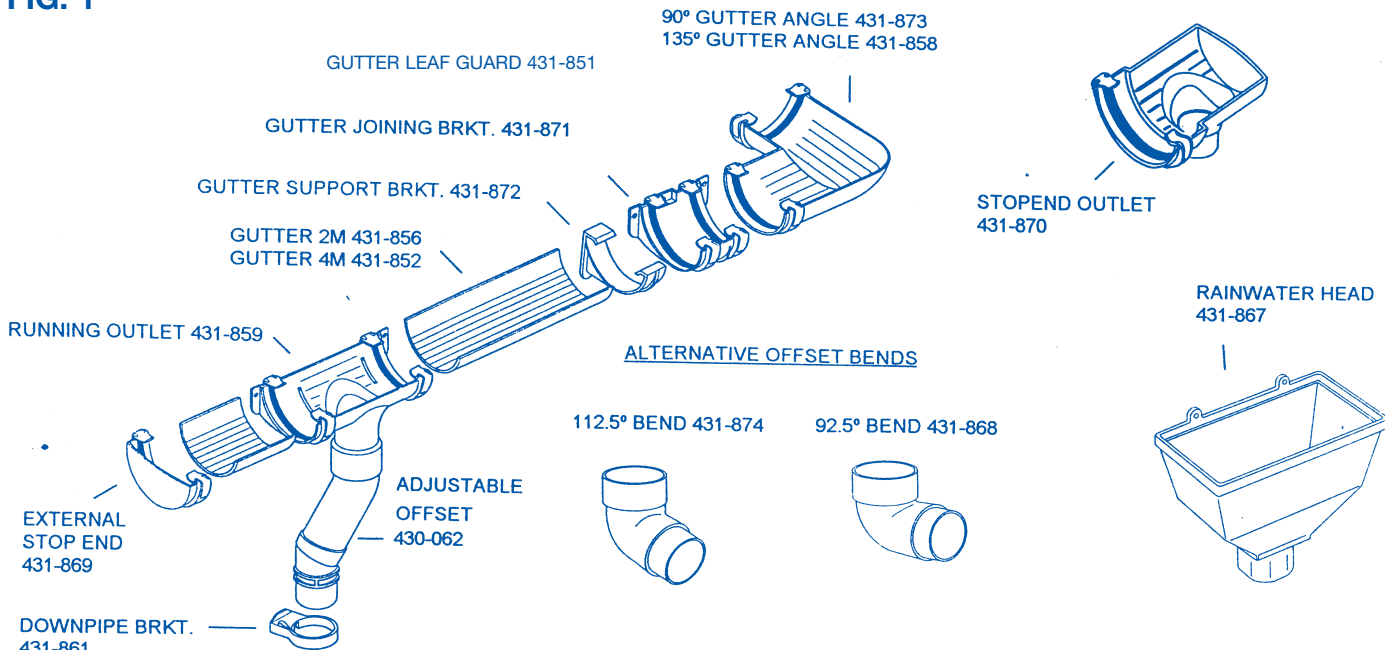

**FIG. 2** ALL PRODUCT CODES SHOWN ARE BLACK

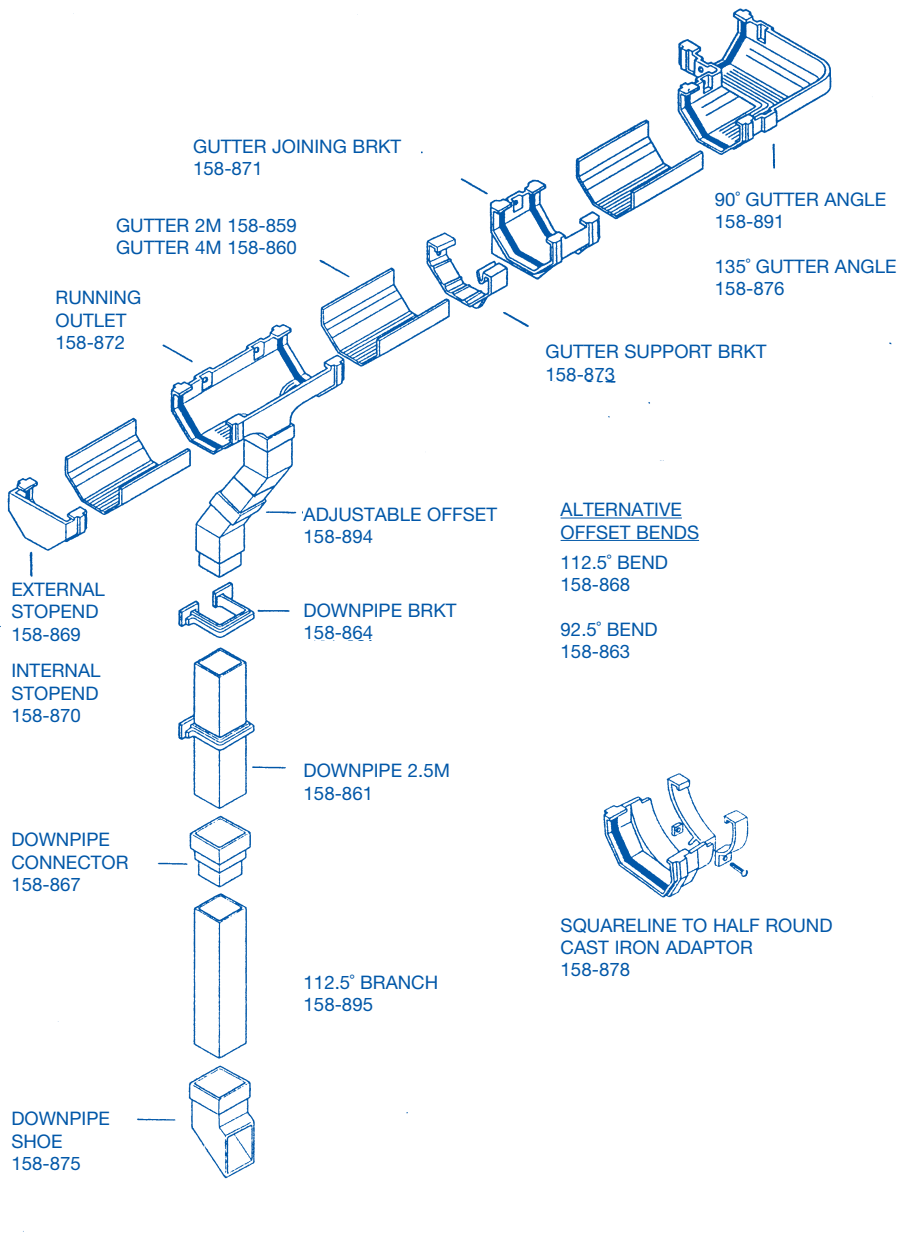

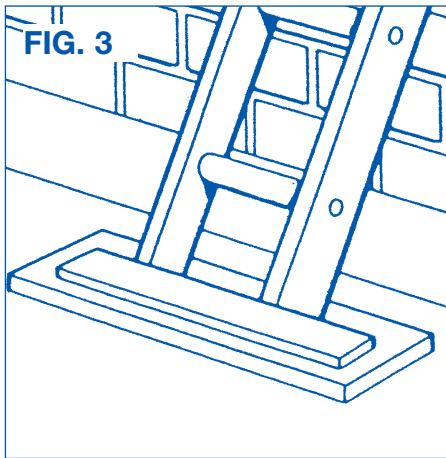

65mm (2½") square downpipe. Squareline is available in Black, White or Brown.

As well as being an alternative to our Roundline system, the greater capacity of the Squareline system means it is suitable for large domestic houses and conservatories, as well as many commercial buildings, such as shops and offices.

Features and Benefits of all rainwater systems

- Compliance with: BSEN607 – Guttering and fittings, BSEN 1462 – Brackets and BSEN 12200 – Downpipes and fittings
- Looks good
- Economical
- Low maintenance
- No painting required
- Lightweight and easy to fit
- Smooth wipe clean surface
- Simple clip together installation

**FIG. 1.** Shows the 112mm Roundline system components.

**FIG. 2.** Shows the 114mm Squareline system components.

Minifit 76mm system components are (the components listed below can be related to FIG. 1):

- 431-802 2m gutter
- 431-808 90° Gutter angle
- 431-809 Gutter joint bracket
- 431-810 Stopend outlet
- 431-811 External stopend
- 431-812 Gutter support bracket
- 431-806 2m downpipe
- 431-807 3m downpipe
- 431-804 Downpipe bracket
- 431-805 112.5° Offset bend

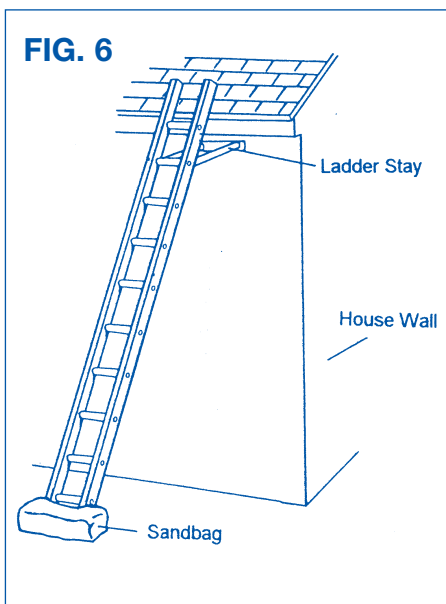
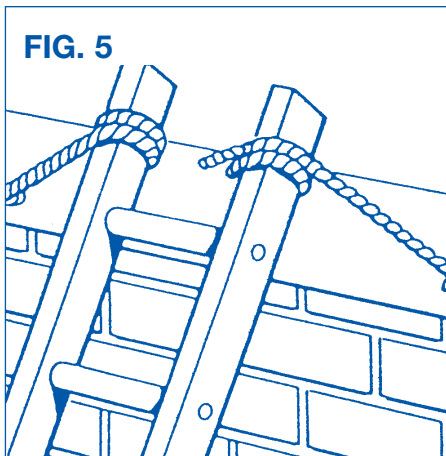
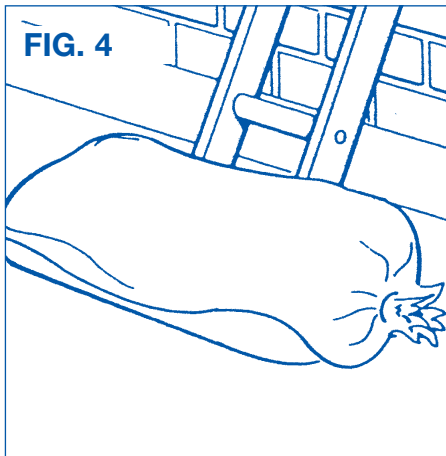

A vast majority of guttering work is carried out at the top of a ladder; every precaution should be taken to ensure that the work is carried out safely. When using a ladder make sure that it is securely based on level ground. If the legs are on cultivated ground, place them on a substantial piece of boarding to (a) spread the loading (b) prevent the risk of the ladder legs sinking into the ground. Seen in **FIG. 3**.

To prevent the foot of the ladder slipping away, place a sandbag or similar heavy object across the base. Seen in **FIG. 4**.

Whenever possible, tie the top of the ladder into ringbolts at eaves level or to an adjacent window frame. Seen in **FIG. 5**.

Use a ladder stay (530-039) to position the top of the ladder away from the eaves overhang, this will enable you to work more safely. Seen in **FIG. 6**.

Always have an assistant with you as the removal and refitting of guttering ideally needs two people working together. Remember to take extra care when removing cast-iron guttering, and downpipes, they are extremely heavy. Although it is light in weight, a length of PVCu guttering could easily be caught in a gust of wind and pull you off your ladder. When working from ladders or platforms, never take chances.

**NOTE:** If you're not an Employer, Employee or Self-employed, the following is still good working practice and should be observed at all times. A few minutes thought and preparation will save you from injury, or worse.

## BEFORE YOU START

If you are simply replacing an old gutter system, you should plan to run a new downpipe to the original drain connections. For new building extensions or conservatories, try to position new gutter outlets so that the downpipes run to an existing gully or drain. Alternatively, install a new gully to the main drainage system or a soakaway may be built and the new connections can run to this. See Good Idea Leaflet 74.

## BUILDING REGULATIONS

With new build situations and any connections to the main drainage system, your local authority must be contacted before you start. For new builds, they will advise you of their requirements for the disposal of surface water when they approve your plans. For additions to the main drainage system, your local Building Control Office will advise you on all requirements. See Good Idea Leaflet 74.

## SAFETY

You should never allow rainwater pipes to discharge over a driveway or path as this will inevitably lead to the growth of slippery algae and also the formation of ice during winter months.

## WORKING AT HEIGHTS – THE FACTS:

- According to the Health & Safety Executive approximately 4,000 people per year suffer from serious injuries and 50 are killed as a result of falling from height.
- Falls are the largest cause of fatalities in the work place.
- 60% of all major injuries are caused from falls below 2 metres.
- Nearly a quarter of all fatalities and major injuries are caused by falls from ladders.
- 46% of fatalities are non-construction related, with highest numbers in the service and manufacturing sectors.

The Working at Height Regulations (WAHR), introduced during 2005, attempt to reduce the number of accidents associated with Working at Height. To achieve this they adopt three basic principles:

- If practicable, avoid working at height
- Use the most suitable equipment and method of work to prevent falls
- Reduce the consequences of any fall by use of appropriate fall arrest systems.

Employers, Employees and the Self-employed undertaking work at height will be affected by the Regulations and should as a minimum, be aware of the following points:

- Consider whether there are safer alternative ways of doing the job.

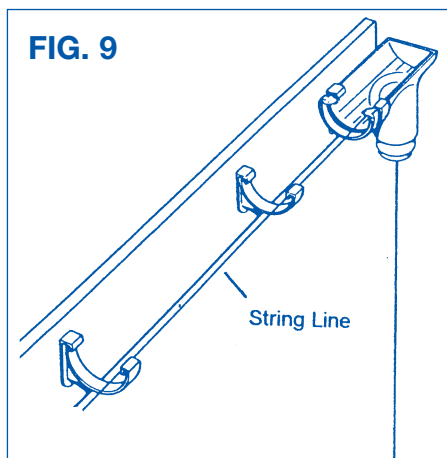
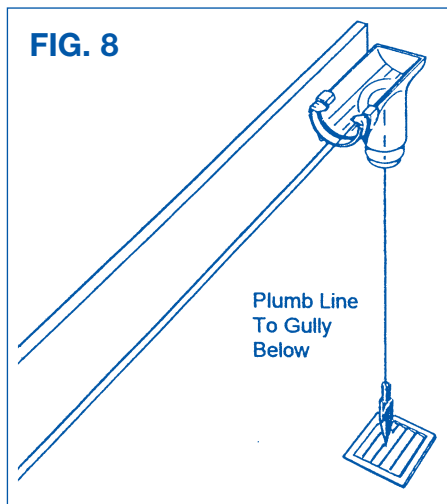
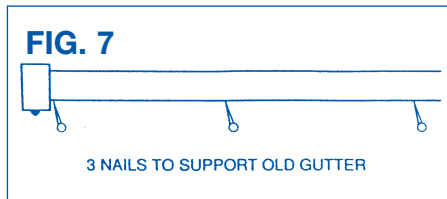

- Don't underestimate the risks involved. Simply 'taking care' is not enough. Proper precautions must be in place.
- Don't start work at height until you have properly planned how you are going to do it, and you have assessed and controlled the risks involved.
- Complete a Risk Assessment incorporating all aspects of the proposed work and the circumstances in which it will be undertaken.
- Ensure that you have fully considered all of the ways in which you could be at risk of falling.
- Record the assessment to demonstrate that the system of work was appropriate and justified.
- Decide what equipment is required for the job. Precautions should be incorporated that will prevent a fall, for example, using guardrails at a roof edge or crawling boards on a fragile roof. For some jobs it may be appropriate to use fall restraint equipment such as a safety harness.
- Don't automatically use a ladder to do a job because one had been used previously. If you have not got the appropriate equipment then get it. Making do without the right equipment too minimise expense can lead to injury

or death, as well as risking prosecution by the authorities.

- Make sure that equipment is in good condition, is used safely and that any necessary training and / or supervision are provided.

## WORK SEQUENCE

1. Calculating materials required & measurements.
2. Removing the old gutter and downpipes (if applicable).
3. Repairing the fascia board where necessary, paint or replace if required.
4. Installing a new gutter system
5. Installing downpipes

### 1. CALCULATING MATERIALS & MEASUREMENTS

All measurement and material calculation can be done at ground level. To calculate the quantity of gutter required simply measure around the relevant elevations of the building. Corners, internal or external, are catered for by using the appropriate 90° or 135° gutter angles. All gutter angles must be fixed to the fascia. Corner angles should be fixed using support brackets not more than 150mm from each end of the fittings.

Sections of gutter are joined together by means of a joint bracket (431-871/158-878). Gutter unions must be fixed to the fascia by means of a gutter support bracket (431-872/158-873).

Wickes guttering systems must be supported by brackets at a maximum of one metre centres. In areas of anticipated heavy snowfall, bracket spacing should be reduced to 750mm centres. Only omit support brackets where gutter angles or joining brackets are fixed directly to the fascia board.

When water collects in the gutter it is fed through an outlet which is in turn connected to a downpipe. If you require an outlet at the end of a gutter run, use the stopend outlet (431-870). Alternatively you may require an outlet to be in from one end or positioned centrally, in which case use a running outlet (431-859/158-872).

All of these components are listed in **FIG. 1 & 2**. Downpipes are joined using straight downpipe connections (431-860/158-867). You will not require a connector when joining the downpipe to a gutter outlet, simply push the pipe over the outlet spigot. If the gutter is fitted on overhanging eaves you will need to form an offset to project the downpipe from the gutter outlet to the house wall. You will require two 112.5° bends to make up a standard offset, the length of the offset can be increased by using a section of downpipe between the fittings.

112.5° offset bends (431-874/158-868, 92.5° bends, (431-868/158-863), as well as an adjustable offset, (430-062/158-894), which may be cut to suit projections between 22mm and 80mm. This is suitable for eaves with a shallow overhang or to offset downpipes over corbelled brickwork.

Downpipe brackets are required at 2 metre intervals. The pipe run may terminate with a shoe to direct the rainwater into a gully. A shoe is not required when a downpipe discharges into a rainwater head or connects directly to a drain.

**NOTE:** When connecting direct to drain, an access point must be provided at the base of the rainwater pipe.

The rainwater head (431-867) can be used to collect rainwater from one or more adjacent downpipes, combining these into one downpipe before connecting to the drain. Alternatively downpipes may be interlinked using a 112.5° pipe branch (431-862/158-895).

All gutter fittings should be fixed securely to a wooden fascia board using: 25mm x No.10 stainless steel round head wood screws.

**NOTE:** If you have PVCu fascia boards, make sure that the supporting gutter brackets are screwed into the solid wood behind, or the whole lot will probably fall down with the first high winds or heavy rain.

Downpipe supports should be fixed using: 32mm x No.10 stainless steel screws into masonry wall plugs.

### THERMAL MOVEMENT

PVCu material is subject to thermal movement. Wickes Gutter joints have been designed to accommodate this without affecting efficiency.

**NOTE:** Before a gutter is locked into the gutter joint, ensure the gutter end is lined up with the 'INSERT TO HERE' line on the inside of the fitting. See **FIG. 10**. Failure to do this could result in either the gutters being forced together through expansion, causing damage and making strange noises in the summer, or falling out in the winter, due to contraction.

Wickes Silicone Lubricant (432-013) should always be used on all gutter seal joints to aid installation and thermal movement; this will also prevent annoying expansion and contraction noises caused by gutters moving across dry jointing seals. Don't use washing-up liquid (which contains salt), or other similar products, as a lubricant, this will cause damage to the seals, resulting in leaks, noise and an early replacement.

Never use oil or grease, as this very quickly ruins the seals.

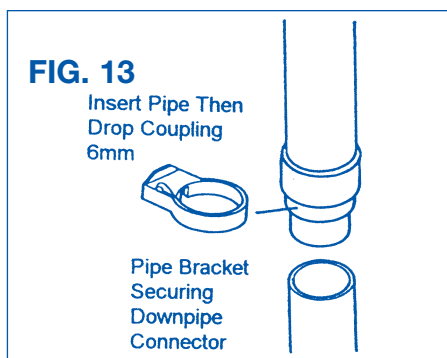
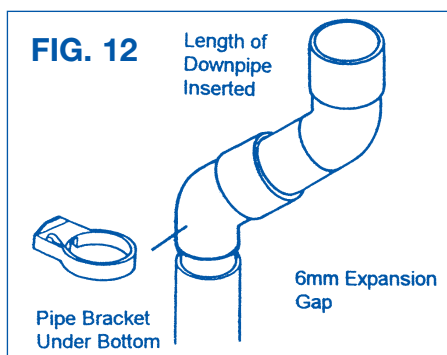
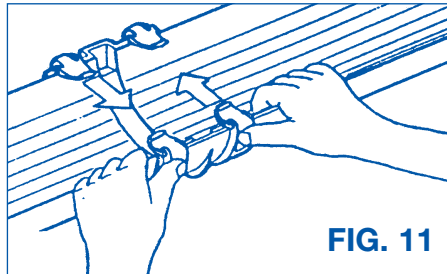
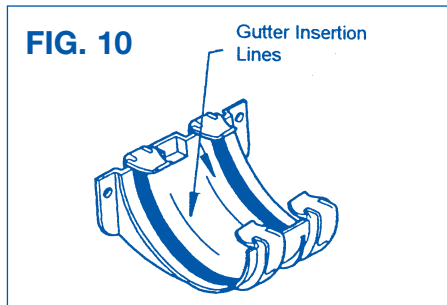

## 2. REMOVING AN OLD GUTTER & DOWNPIPES

Some gutters, especially cast iron, will be heavy and difficult to manage. Although most of the gutter should be supported with gutter brackets, some sections such as stopends may not. When dismantling the gutter, any unsupported sections should be supported using 150mm nails driven into the fascia underneath the gutter. See FIG. 7.

The bolts used in the joining of metal gutter sections will probably be rusted and need to be cut off with a hacksaw, or drilled out. Once the bolts have been removed, the mastic or putty seal, used to join lengths of gutter, will break away easily. Remove the gutter, section by section, and independently lower each piece to the ground.

Once a length of gutter has been removed, the fascia support brackets may be unscrewed and discarded. Continue this sequence until you reach the end of the

gutter. Some sections of gutter or downpipe may be badly rusted together. If this is the case, the joint will have to be carefully broken up using a hammer and chisel.

Cast iron downpipe brackets were often fixed using masonry 'pipe nails'. The nails can prove difficult to remove and may need to be driven out using a hammer and cold chisel.

**NOTE:** In both cases safety glasses and gloves should be worn.

Old plastic gutter systems can be easily removed, simply unclip the gutter joints and support brackets and remove each section of gutter. Gutter fittings may then be unscrewed and discarded. Jointing materials are not normally used on PVCu downpipes, they should just pull apart during disassembly. Any joints that appear to be glued will have to be cut out using a fine toothed saw.

## 3. RENOVATING THE FASCIA BOARD

When the old gutter and downpipes are removed, the fascia may now be refurbished. Any defects in the timber, such as screw holes and cracks, should be cleaned and filled with an appropriate wood filler. You may find patches of wet rot; again this must be thoroughly cleaned then filled. Severely rotted timber should be cut out and replaced either with preservative treated timber or Wickes low maintenance PVCu products.

If the painted finish of the fascia is in poor condition, it should be stripped, the wood and any filler rubbed down, and a coat of preservative applied before repainting. Treat bare timber with Wickes Woodcare Basecoat followed by Woodcare Topcoat rather than conventional paint.

This could be a good time to replace tired wooden Fascias and Soffets with Wickes easy to use, low maintenance PVCu products. See Good Idea Leaflet 104 for more details.

## 4. INSTALLING THE NEW GUTTER SYSTEM

Your gutter system may be installed level or to a maximum fall of 3mm per metre.

**NOTE:** However fitted, the bottom of the roof tile and the top edge of the gutter must never be more than 30mm (1¼") apart.

### FIXING PROCEDURE

Use a plumbline centred over the gully or drain connection to establish the position of your first outlet. See FIG. 8.

Fix the outlet to the fascia to suit level fixing or gutter with a fall. Next, fix a support bracket about 55mm from the end of the fascia board, furthest from the outlet. When using a single screw fixing bracket to secure the string line, take care not to twist the bracket. By positioning the bracket towards the top of the fascia, you will create a fall on your gutter. The fall can be checked by running a taut stringline between the two fittings and resting a spirit level on the string. The line will also help you position your next fitting at the right level. See FIG. 9.

If you require a level gutter, fix the support bracket level with the gutter outlet. Again, run a taut stringline between the two fittings and tie it off, this will act as a level and help you in the positioning of the next fitting. See FIG. 9.

Using the stringline as a guide position support brackets at one metre intervals starting from the outlet. Remember to fix all joining brackets or unions to the fascia. Once all the support fittings are in place the gutter may be cut to suit and installed. At the ends of a gutter runs you may terminate the gutter with an external stopend. Position the stopend about 50mm (2") past the end of the tile edge, this should help collect water swept from the roof by the wind.

To calculate how long a section of gutter needs to be between two fittings, measure the distance between 'insert to here' lines on the inside the fittings. See FIG. 10. This will give you the exact length at which the gutter must be cut. This will also allow for expansion and contraction movement of the gutter.

Mark the gutter with a pencil and cut to length using a fine toothed saw (a single screw bracket can be used as a saw guide when cutting gutter to the required length). Carefully remove any burrs or rough edges with a file or sharp knife. Apply Wickes silicone lubricant to the joint seals, and then install gutter into the relevant section. To install the gutter into a fitting, insert the rear edge of the gutter under the back retaining lip of the fitting. Ensure that it is fully home, This is even easier with The Wickes system gutters. Simple wing clips are used to hold the guttering in place in most connectors. This prevents sore fingers. See FIG. 11.

If you are installing guttering around a corner, secure your gutter angle in position and repeat the fixing procedure as before.

## 5. INSTALLING DOWNPIPES

Buildings with very shallow eaves, such as garages, extensions and conservatories, may not need an offset to connect the gutter outlet to the downpipe. However, if a small offset is required, then our adjustable offset should be used (430-062). This is a two piece fitting that is simply cut to suit, then fitted.

A standard domestic property will normally have a larger eaves overhang. If this is the case, you will need to use the 112.5° or 92.5° offset bends. An offset may be formed by cutting a piece of downpipe at the required length and fitting it between the two bends. See FIG. 12. To give the offset maximum support, fit a downpipe bracket directly around the lower offset bend.

When connecting the next section of pipe to the lower offset bend, fit the pipe over the bend spigot, but do not push fully home; allow for an expansion gap of approximately 6mm. This should be allowed for at every bend, branch or connector, as also shown in FIG. 12.

# Compatibility Chart

Manufacturer	Wickes Roundline	Wickes Squareline
BRETT	YES	NO
FLOPLAST	YES	NO
HUNTER	YES	YES
HEPWORTH	YES	YES
MARLEY	YES	NO
OSMA	YES	NO
POLYPIPE	YES	NO
TERRAIN	NO	NO

Sections of pipe can be joined using downpipe connectors. Each time a connector is used it must be supported with a downpipe bracket. See **FIG. 13**. Pipe support brackets must be fitted between downpipe connectors at a maximum spacing of 2 metres. If your downpipe is to discharge over an open topped gully, then finish your downpipe with a rainwater shoe. This will direct the water over the gully grating. The shoe will require support of a pipe bracket.

If you are to connect the downpipes directly to the drain, then use our drain adaptor (432-009). Roundline downpipe will simply push into the drain adaptor socket. Using a solvent welded joint, the drain adaptor will connect your rainwater pipe to 110mm PVCu underground drainage pipe. See **FIG. 1 & 2**.

**Wickes Rainwater Gully:**  
Another choice is to use the Wickes Rainwater Gully (158-828). This has the advantage of fitting flush with the ground and has an access plate for easy removal of debris from the its integral debris catchment chamber, making it ideal for soakaways and main drainage alike. Wickes 68mm Roundline Downpipes fit directly into this unit. There is a 110mm outlet (spigot) for direct underground connection.

**NOTE:** This Gully should only be used for surface water (rain), never foul water (household waste) applications.

Both the Roundline and Squareline systems offer a PVCu to half round cast iron gutter connector (431-853 and 158-878). They can be used on terraced or semi-detached properties, when you will need to connect from your new gutter to neighbouring gutters. This adaptor is not limited just to cast iron; it will fit most 4-4½" nominal gutters of any material. Gutter mastic is required when joining this fitting to existing gutters.

Wickes gutters can be directly connected to many other manufacturers plastic gutters, without the need for special connectors. See the compatibility chart overleaf which lists the gutter systems on the market with which they are compatible.

If you live in an area where birds and squirrels sit on your roof, or you have trees nearby, fitting Wickes Gutter Leaf Guards (431-851) onto your guttering could save you a lot of time and effort clearing gutters and drains each year. They aren't very expensive, and are extremely effective at keeping everything clear. If you have soakaway drains, they're essential.

## GUTTER MAINTENANCE

A whole range of debris can collect in gutters: twigs, silt, weeds, moss, leaves, lichens etc. It only takes one small obstruction to have a dramatic effect on water flow to the downpipes. Lift out any large pieces of debris; remove smaller pieces with a hand brush and small garden trowel, after this, any moss or lichens may need scrubbing with a brush and soapy water to loosen them.

Visually check all brackets are secure. That none of the gutters or downpipes are loose, cracked, or seals any have become dislodged. Look for staining along the underside of the guttering as this is the first sign of a leak. If in doubt, test by pouring some water into the gutter. If a leak is found, reposition or replace the seal or gutter length, depending on the type or position of the leak. Replace any corroded screws (if you've not used stainless steel).

Whilst every care has been taken to ensure that the product design, descriptions, specifications and techniques of constructing the products are accurate at the date of printing. Wickes products will inevitably change from time to time and the customer is advised to check that the design, descriptions, specifications and techniques of constructing any of the products described in this leaflet are still valid at the time of purchase or placing an order.

© Wickes Building Supplies Limited 2011

All rights reserved. No part of this publication may be produced or transmitted in any form or by any means electronic, mechanical, photocopying, recording or otherwise or stored in any retrieval system of any nature without the written permission of the copyright holder and the publisher.