

## HOW TO BUILD A PARTITION WALL

Building a non-load bearing partition wall either part or all the way across a room can often help to make more practical use of available space. Youngsters can perhaps be provided with a more secluded study

or play area, or maybe a separate washing or shower area in a bedroom can be constructed. Such walls can also be used as the dividing but not loadbearing walls in a home extension.

The simplest way to make partition walls is to construct a framework to which plasterboard can be fitted on each side. Traditionally timber is used for making the framework.



### TIMBER STUD PARTITIONS

These are constructed entirely of timber and either 9.5 or 12.5mm plasterboard. All timber (generally 44 x 69mm finished size PSE, 47 x 75mm finished size sawn timber or 36 x 63mm studwork timber is specified) is simply nailed together, with only the head and sole plate being screwed or nailed to the ceiling and floor. The studs (verticals) need to be accurately cut to length, and horizontal noggins need to be fitted between studs for rigidity and for the fixing of heavy wall mounted items such as basins or cupboards. Where services like water pipes or electric cables need to be run inside the framework, the studs must be drilled out to accommodate them.

**Nevertheless** a timber frame is easy to assemble.

**Note: 12.5mm Plasterboard will reduce the transmission of sound**

### CONSTRUCTING A TIMBER STUD PARTITION WALL

You will require sufficient 44 x 69mm finished size PSE (Planed, Square Edge), 47 x 75mm finished size sawn timber or 36 x 63mm studwork timber, for the head and sole plates, and for the studs and noggins.

**When using 12.5mm plasterboard** the studs must be at maximum 600mm centres. **If using 9.5mm plasterboard** the studs must be spaced at maximum 400mm centres. Plasterboard standard sheet size is 1200 x 2400mm.

**The list** overleaf gives the products required for a 3.6m long wall.

**Use the 'I NEED'** column to make up your own list for a wall of a different length.

### SPECIAL TOOLS REQUIRED

**A plumb bob** and line, plus a caulking tool (600-546) are the only special tools required.

### WORK SEQUENCE

1. Secure head and sole plates.
2. Secure studs and noggins.
3. Secure plasterboarding.
4. Make good.

#### KEEP INFORMED

- Look for other Good Idea Leaflets that could help you with your current project.
- Check that your Good Idea Leaflets are kept up to date. Leaflets are regularly changed to reflect product changes so keep an eye on issue dates.
- If you would like to be put on our mailing list for the Wickes Catalogue call

**0845 274 1000**

- Visit our website  
**wickes.co.uk**

PROJECT SHOPPING LIST			
PRODUCT DESCRIPTION	BOOKLET CODE NO.	QTY REQD FOR THIS PROJECT	I NEED
2.4m lengths timber for studs, heads and sole plate and noggins 44 x 69mm PSE pk3 OR 47 x 75mm kiln dried sawn single OR 36 x 63mm studwork timber 14 lengths of either of the above if using 9.5mm plasterboard 11 lengths of either of the above if using 12.5mm plasterboard	107-042  107-115  107-177		
Sheets 1200 x 2400 x 12.5mm tapered edge plasterboard OR Sheets 1200 x 2400 x 9.5mm tapered edge plasterboard	220-210	6	
	220-207	6	
Plasterboard jointing tape 150m roll	220-215	1	
10Kg Jointing Compound	220-995	1	
Drywall Screws			

### 1. SECURE HEAD AND SOLE PLATES

Start work by locating the position of joists in the ceiling roughly where you want the partition to be. If the joists run in the opposite direction to the intended new wall you will be able to fix a head plate to each joist at approximately 405mm centres using 100mm oval nails, or screws if the ceiling is in poor condition and likely to be damaged by hammering.

If the joists run in the same direction you should slightly alter the new wall position so that it is directly under a joist and the head plate can be fixed directly to it. If this is not possible, noggins will have to be fitted between the ceiling joists to enable fixings to be made.

When the head plate is fixed, drop a plumb bob and line down to floor level from one side of the head plate at each end and mark the position of the sole plate on the floor. **Diagram A.**

Nail the sole plate directly to a timber floor or drill, plug and screw into a concrete floor.

### 2. SECURE STUDS AND NOGGINS

Mark the positions of the vertical studs on the sole plate. The first will be against the end wall and screwed to the wall.

It may be necessary to shape this length to fit around a skirting board. The second stud must be positioned so that it's centre is 600mm from the wall, and the third stud centre is at 1200mm from the wall with 600mm centres thereafter. **Diagram B.** If using 9.5mm plasterboard an extra stud is required and the stud

centres must be 400mm.

Measure and cut each stud individually since the distance between the head and sole plates may vary across the room. The studs should be a tight fit. Secure the studs using 100mm oval nails driven in at an angle. **Diagram C.**

Make small pencil marks on the wall and floor at the centre of each stud on each side of the frame so that locating them when fitting the plasterboard will be easier.

NOTE: Studs must be positioned wherever sheets of plasterboard are to join and must be in the centre of the join including above a door frame.

Cut noggins to fit between the studs and nail in place roughly halfway up the frame, and where heavy items are later to be hung on the wall. **Diagram D.**

### 3. SECURE PLASTERBOARDING

Fit the plasterboard, ivory face out, ensuring that each sheet is perfectly vertical and that adjacent sheets meet at the centre of a stud. Using wedges, lift the sheets so that they touch the ceiling rather than the floor. Skirting board will be used to conceal any gap at the bottom.

Secure the boards with Drywall screws at 300mm centres all round the perimeter and to intermediate studs. Reduce the centres to 200mm in the corners of the plasterboard. The screws should be driven in just below the surface.

### 4. MAKE GOOD

Once all boards are secured it is necessary to make good all joins and infill screw heads.

Apply a thin coat of jointing compound to the joins and bed paper jointing tape into this. Apply more compound over the surface and finish flush with the board surface using a wide bladed caulking tool. **Diagram E.**

This is simply a form of smoothing trowel which spans the tapered edges of the board and gives a smooth flat finish to the filler. Caulking tools are stocked by Wickes. To avoid unnecessary rubbing down when the filler has dried do not overfill. A little rubbing down will be necessary to create a perfect flat finish. Cover nail heads also, flush with the surface of the board. Fill in joins between the new wall and the old. At ceiling level, bond coving in place and at floor level fit skirting boards. The plasterboard needs no further preparation before normal decorating takes place.

### FITTING DOORS

Doors can easily be built into a partition wall. Construct the wall leaving an opening with studs on each side and a noggin across the top. The opening dimensions should be as indicated in **Diagram F.** Fit one of our interior door casings into the opening securing the casing directly to the studs.

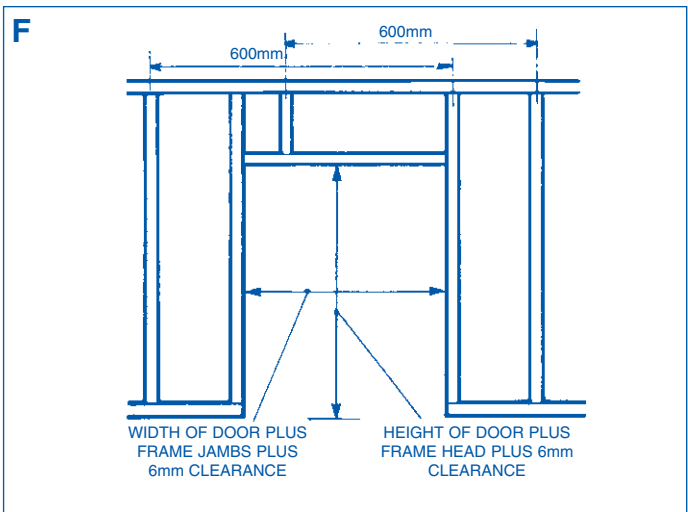
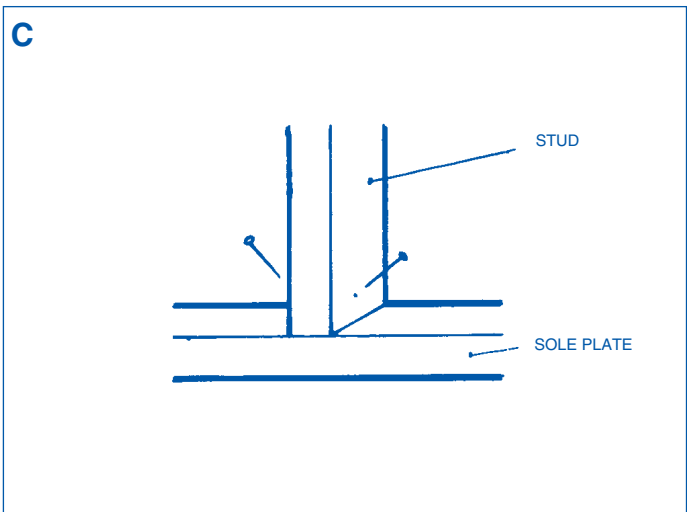
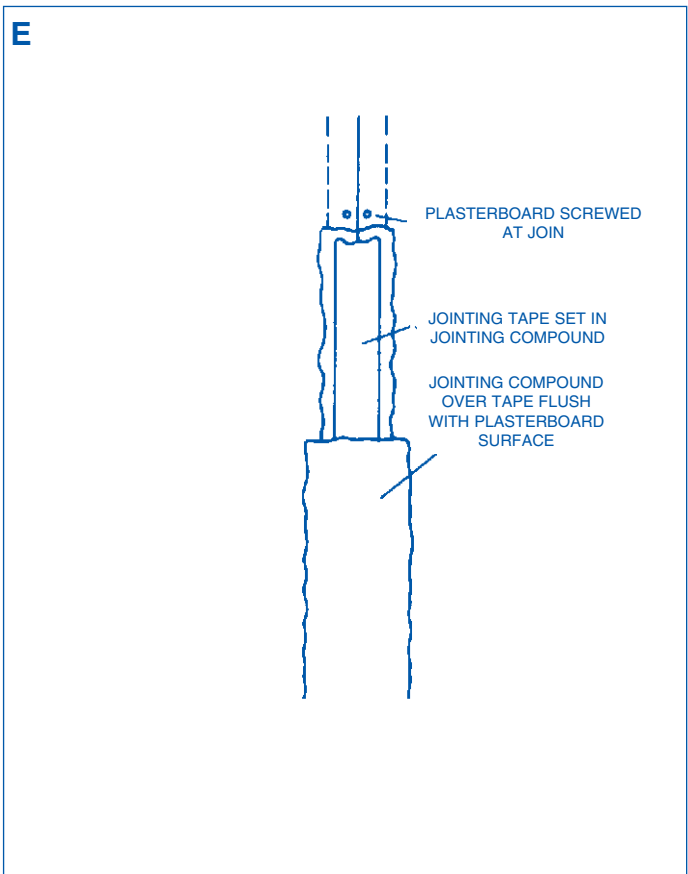
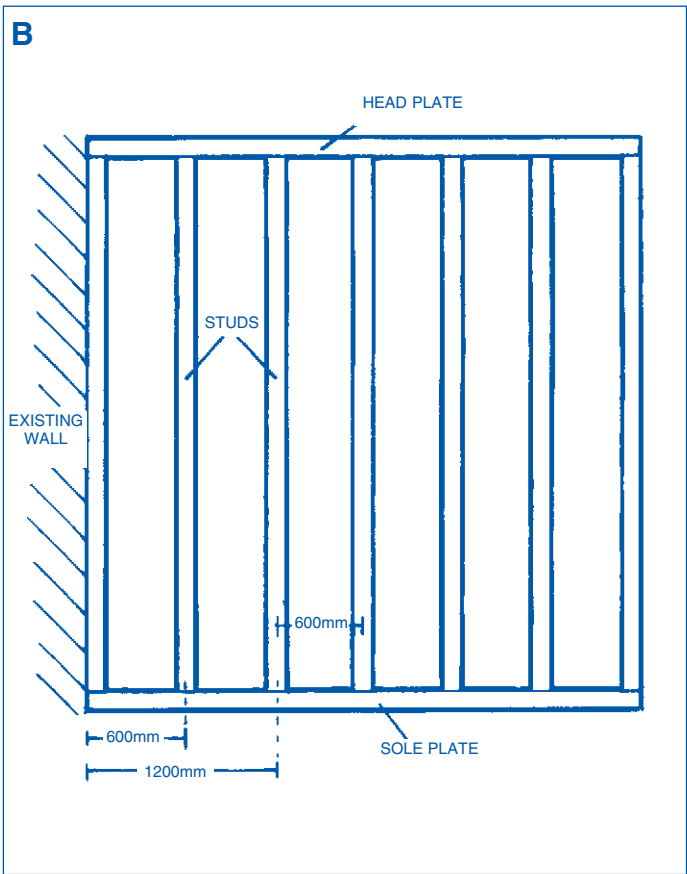
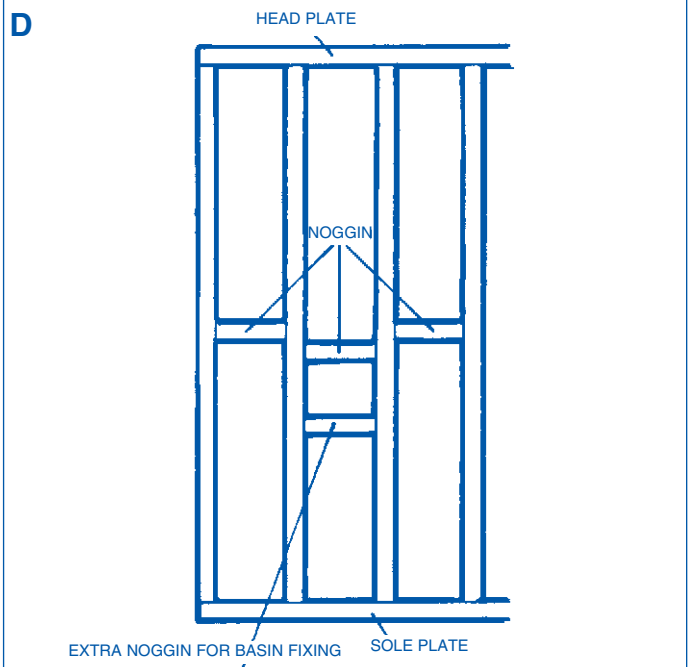
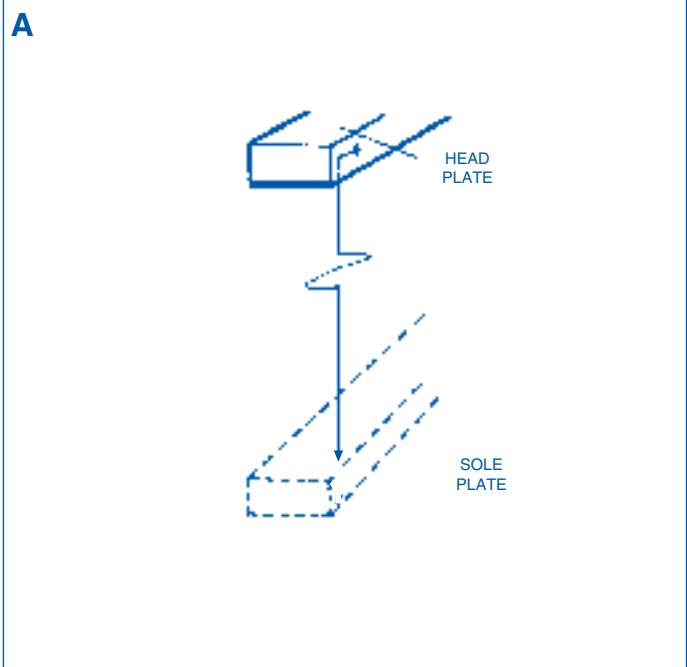

## PLANNING

Every job needs careful planning, use this leaflet and a copy of the Wickes booklet to help you price your project.

### NOTES

### COSTS

## METRIC CONVERSIONS

Inches	Millimetres	Feet	Metres	Sq Feet	Sq Metres	Pounds	Kilograms	
0.039	1	25.400	3.281	1	0.305	10.764	1	0.454
0.079	2	50.800	6.562	2	0.610	21.528	2	0.907
0.118	3	76.200	9.843	3	0.914	32.292	3	1.361
0.157	4	101.600	13.123	4	1.219	43.056	4	1.814
0.197	5	127.000	16.404	5	1.524	53.820	5	2.268
0.236	6	152.400	19.685	6	1.829	64.583	6	2.722
0.276	7	177.800	22.966	7	2.134	75.347	7	3.175
0.315	8	203.200	26.247	8	2.438	86.111	8	3.329
0.354	9	228.600	29.528	9	2.743	96.875	9	4.082

Whilst every care has been taken to ensure that the product design, descriptions, specifications and techniques of constructing the products are accurate at the date of printing, Wickes products will inevitably change from time to time and the customer is advised to check that the design, descriptions, specifications and techniques of constructing any of the products described in this leaflet are still valid at the time of purchase or placing an order.

© Wickes Building Supplies Limited 2011

All rights reserved. No part of this publication may be produced or transmitted in any form or by any means electronic, mechanical, photocopying, recording or otherwise or stored in any retrieval system of any nature without the written permission of the copyright holder and the publisher.